

# MDCKB1-120081 120VAC, 8A Brushless Controller

## User's Guide

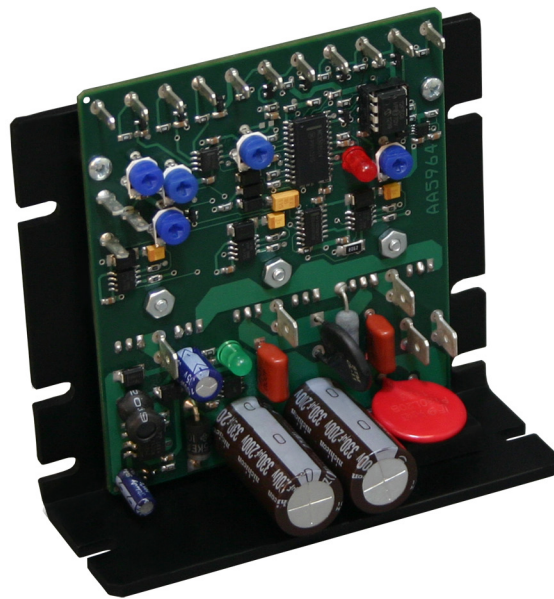

**ANAHEIM AUTOMATION**

4985 E. Landon Drive Anaheim, CA 92807  
e-mail: [info@anaheimautomation.com](mailto:info@anaheimautomation.com)

(714) 992-6990 fax: (714) 992-0471  
website: [www.anaheimautomation.com](http://www.anaheimautomation.com)

## MDCKB1-120081 Driver Features

- Maximum Current Limit from 1.0-8.0 Amps (peak)
- External 5K Potentiometer Speed Control
- Internal Max and Base Speed Adjustment
- 2-Quadrant Operation
- Hall Sensor Feedback
- Constant Velocity Mode
- Short Circuit Protection
- Requires 90-120 VAC
- Brake, Disable and Direction Inputs
- TTL-CMOS Compatible Inputs
- Compact Size (4.3"x4.09"x1.77")
- Dual Mounting Option
- Optically Isolated Analog Voltage Speed Control (*optional*)

## General Description

The MDCKB1-120081 driver is designed to drive DC Brushless motor at currents of up to 8A (peak) and 160V. Using hall sensor feedback, a constant velocity mode can be selected. The driver is protected against over current (cycle-by-cycle), hall sensor error and under voltage. When an error occurs, a fault light is turned on to notify the user. Included on the driver are internal potentiometers to control the maximum phase current allowed into the motor, the maximum speed of the motor, the base speed of the motor and closed loop compensation. An external potentiometer (5K) is used to control the speed as well. The direction of the motor can be preset by the direction control input. Other inputs to the drive include a run/stop and a motor enable input. When using the run/stop input, it overrides all other inputs into the driver.

## Fault Protection

This driver is equipped with a FAULT LED to alert the user of the following conditions.

1. Invalid Hall Sensor Input code
2. Over Current. The driver is equipped with cycle-by-cycle current limiting
3. Undervoltage Lockout activation at 30VAC for the input voltage and 4.5VDC for Hall Sensor power output voltage.

**Caution:** The MDCKB1-120081 driver does not have an internal fuse. To protect the driver from major motor failures, an external fuse greater than the application maximum load current is needed. The MDCKB1-120081 driver is not line isolated. Use only mechanical switches for the control inputs. The terminals of motor connector contains high voltage. Do not probe any part of the driver with power on, this could damage the drive or result in body injury.

## Ordering Information

Part #	Description
MDCKB-120081	120VAC DC Brushless Driver at 8A
MDCKB1-120081-01	120VAC Open Loop Only DC Brushless Driver at 8A
PWR-10EMC1	Dual Stage RF   Power Line Filter.

## Specifications

### Control Inputs: (QD12, QD13, QD16-QD19)

External Switch Compatible

Note: The MDCKB1-120081 driver is not line isolated. Use only mechanical switches for the control inputs. The terminals of motor connector contains high voltage. Do not probe any part of the driver with power on, this could damage the drive or result in body injury.

### Run/Stop: I1 and I2 (QD12 and QD13)

Switch Open - Motor will not run and if running will decelerate rapidly

Switch Closed - Motor will run

### Direction Control: D1 and D2 (QD16 and QD17)

Switch Open - Clockwise

Switch Closed - Counterclockwise

### Enable Control: E1 and E2 (QD18 and QD19)

Switch Open - Motor is Enabled

Switch Closed - Motor is de-energized and will coast

### Speed Adjustment Control: P1-P3 (QD9-QD11)

The external speed control potentiometer must be 5K Ohms.

P3 (QD9) - Pot (+)

P2 (QD10) - Pot Wiper

P1 (QD11) - Pot (-)

### Output Current Rating:

Adjustable 2.0 - 8.0 amperes per phase maximum operating peak current

(1.0 - 4.0 amperes per phase maximum operating continuous current)

### Power Requirements: L1 and L2 (QD14 and QD15)

90VAC (min) - 135VAC (max)

**Caution:** The MDCKB1-120081 driver does not have an internal fuse. To protect the driver from major motor failures, an external fuse greater than the application maximum load current is needed.

### Operating Temperature:

Heat Sink: 0° - 70°C

### Hall Sensor Power Output:

6.25V @ 30mA maximum. Typical current draw from hall sensors is 20mA.

All three Hall Sensor inputs are pulled up through 20K ohm resistors.

Only the Motor Hall Power wire should be tied here.

## Commutation Sequence

	Step					
	1	2	3	4	5	6
Phase A	+	Z	-	-	Z	+
Phase B	Z	+	+	Z	-	-
Phase C	-	-	Z	+	+	Z
Hall A	1	1	0	0	0	1
Hall B	0	1	1	1	0	0
Hall C	0	0	0	1	1	1

120° Hall Spacing Sequence Forward

	Step					
	1	2	3	4	5	6
Phase A	-	Z	+	+	Z	-
Phase B	Z	-	-	Z	+	+
Phase C	+	+	Z	-	-	Z
Hall A	1	1	0	0	0	1
Hall B	0	1	1	1	0	0
Hall C	0	0	0	1	1	1

120° Hall Spacing Sequence Reverse

	Step					
	1	2	3	4	5	6
Phase A	+	Z	-	-	Z	+
Phase B	Z	+	+	Z	-	-
Phase C	-	-	Z	+	+	Z
Hall A	1	1	1	0	0	0
Hall B	0	1	1	1	0	0
Hall C	0	0	1	1	1	0

60° Hall Spacing Sequence Forward

	Step					
	1	2	3	4	5	6
Phase A	-	Z	+	+	Z	-
Phase B	Z	-	-	Z	+	+
Phase C	+	+	Z	-	-	Z
Hall A	1	1	1	0	0	0
Hall B	0	1	1	1	0	0
Hall C	0	0	1	1	1	0

60° Hall Spacing Sequence Reverse

+ = Top Transistor ON, Bottom Transistor OFF, Current Flows into this wire

- = Top Transistor OFF, Bottom Transistor ON, Current Flows out of this wire

Z = Top Transistor OFF, Bottom Transistor OFF, No current into or out of this wire (High Impedance)

## Motor Connection

Refer to the hookup diagram for typical driver applications. When connecting a motor for the first time, connect the hall sensor wires (5 of them) to the driver. **DO NOT CONNECT THE PHASES YET.** Turn on power and rotate the motor by hand. If the RED FAULT LED turns on, the hall phases are incorrectly wired. If the RED FAULT LED does not turn on, then the hall wires are connected correctly. Power the unit down and proceed to connect the motor phases. If the motor does not run or runs erratically, power down and check the speed potentiometer and make sure the phases are connected correctly. There are only 6 different ways to connect the phase wires, and normally only two will allow the motor to rotate, but only one is correct. If the direction of the motor is changed and the no-load current of the motor is approximately the same and the motor runs smoothly in both directions then the phase wires are correct. If the motor still runs erratically, adjust the close loop compensation potentiometer R11.

The wiring of the motor phases should be separated from the hall and input connections to not allow a possible source of interface.

Note: The MDCKB1-120081 driver is not line isolated. Use only mechanical switches for the control inputs. The terminals of motor connector contains high voltage. Do not probe any part of the driver with power on, this could damage the drive or result in body injury.

## Closed Loop Compensation and Rated Motor Speed Range Adjustment:

1. Start with setting the external speed potentiometer to 50%, closed loop adjustment potentiometer R11 at 50%, minimum motor speed potentiometer R25 at 50%, maximum motor speed potentiometer R17 at 50%, and current limit potentiometer at 100%. The motor might be cogging at first.

POT #	Description	Setting
R11	CLADJ	50%
R14	RAMP	50%
R17	Max Speed	50%
R25	Min Speed	50%

2. If the motor is cogging, slowly lower closed loop adjustment potentiometer R11 until the motor stops cogging and operates smoothly. The motor should not be stalled, running maximum open loop speed, or cogging. R11 must be set where the motor should be running smoothly. If the motor is not cogging, proceed to step 3.
3. Set the external speed potentiometer to 50%. Set the minimum motor speed by adjusting potentiometer R25 according to user application. The minimum running speed should be set to a speed higher than 0RPM. The run/stop switch should be used to brake the motor for 0RPM.
4. Slowly raise the external speed potentiometer to 100%. The motor may be operating at maximum open loop speed.
5. Set the maximum rated motor speed by adjusting potentiometer R17 according to user application. If R17 is set to the maximum setting and a slower speed is required, adjust R11 for slower maximum motor speed.

Note: A different speed range, maximum speed, or minimum speed can be attained by further adjusting R11, R17, and R25.

## Open Loop Only Driver (MDCKB1-120081-01) Rated Motor Speed Range Adjustment:

1. Set the external speed potentiometer to 50%. Set the minimum motor speed by adjusting potentiometer R25 according to user application. The minimum running speed should be set to a speed higher than 0RPM. The run/stop switch should be used to brake the motor for 0RPM.
2. Slowly raise the external speed potentiometer to 100%
3. Set the maximum rated motor speed by adjusting potentiometer R17 according to user application. If R17 is set to the maximum setting and a slower speed is required, adjust R11 for slower maximum motor speed.

Note: A different speed range, maximum speed, or minimum speed can be attained by further adjusting R17, and R25.

Note: The MDCKB1-120081 driver is not line isolated. Use only mechanical switches for the control inputs. The terminals of motor connector contains high voltage. Do not probe any part of the driver with power on, this could damage the drive or result in body injury.

Note: The MDCKB1-120081 driver is not line isolated. Use only mechanical switches for the control inputs. The terminals of motor connector contains high voltage. Do not probe any part of the driver with power on, this could damage the drive or result in body injury.

## **Speed Adjust Setting**

The maximum speed of the motor is set by adjusting R17. The minimum speed of the motor is set by adjusting R25. An external 5Kohm potentiometer is used to adjust the motor speed between the set minimum and maximum speed.

If the Optically Isolated Analog Voltage Speed Control Board (MDCKB1-AIB) is used, R17 must be turned fully clockwise and R25 must be turned fully counter clockwise. An analog 0-5V signal can be used to control the speed of the motor. A user provided 5V supply must be used to power the MDCKB1-AIB board.

## **Motor Run/Stop**

The motor run/stop feature allows the stopping of a motor by shorting out the bottom drives of the three phases. Shorting QD12 and QD13 together allows the motor to run, while an open input does not allow motor operation and if operating causes rapid deceleration.

## **Motor Direction**

The motor direction feature allows the changing of the rotation of the motor. This input should not be changed while motion is in progress. Shorting QD16 and Q17 together causes the motor to turn in the CW direction, while an open between QD16 and QD17 causes the motor to turn in

## **Motor Enable**

The motor enable feature allows the de-energizing of the motor phases. This input can be changed while motion is in progress. Shorting QD18 and QD19 together causes the motor to de-energize, while an open between QD18 and QD19 causes the motor to run at the given speed. To run motor again.

## **Heating Considerations**

The temperature of the heat sink should never be allowed to rise above 70 degrees Celsius. This may occur with motor currents higher than 6A. If necessary, mount the unit to an additional heat sink or air should be blown across the heat sink to maintain suitable temperatures.

Note: The MDCKB1-120081 driver is not line isolated. Use only mechanical switches for the control inputs. The terminals of motor connector contains high voltage. Do not probe any part of the driver with power on, this could damage the drive or result in body injury.

## Terminal Descriptions

QD#	Board Designator	Description
1	HP	Hall Sensor (+)
2	HA	Hall Sensor A
3	HB	Hall Sensor B
4	HC	Hall Sensor C
5	HG	Hall Sensor (-)
6	PA	Phase A
7	PB	Phase B
8	PC	Phase C

QD#	Board Designator	Description
12	I1	Brake 1
13	I2	Brake 2
14	L1	Line HOT
15	L2	Line Neutral
16	D1	Direction 1
17	D2	Direction 2
18	E1	Enable 1
19	E2	Enable 2

QD#	Description
9	+4.0V (Pot Top)
10	Pot Wiper
11	GND (Pot Bottom)

Note: The MDCKB1-120081 driver is not line isolated. Use only mechanical switches for the control inputs. The terminals of motor connector contains high voltage. Do not probe any part of the driver with power on, this could damage the drive or result in body injury.

## Quick Disconnect Mating Connectors

For QD1-QD5, QD9-QD11, QD12-QD13, QD16-QD19:

Panduit # DNF18-110-M. Female Disconnect, nylon barrel insulated, funnel entry, 22 - 18 AWG, .110 x .032 tab size.

For QD6-QD8, QD14-QD15:

Panduit # DNF14-250FIB-3K. Female disconnect, (standard receptacle housings), nylon fully insulated, funnel entry with insulation support and internal wire stop. 16 - 14 AWG wire range, .250 x .032 in. (6.3 x 0.8mm) tab size.

## Quick Disconnect/Potentiometer Location

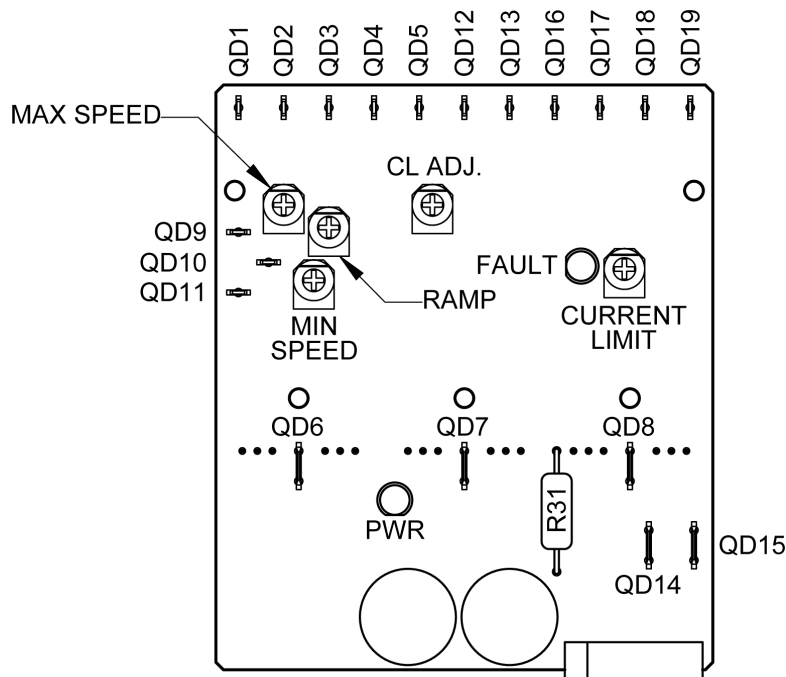

POT#	Description
R11	CLADJ
R14	RAMP
R17	Max Speed
R23	Current Limit
R25	Min Speed

# Wiring Diagram

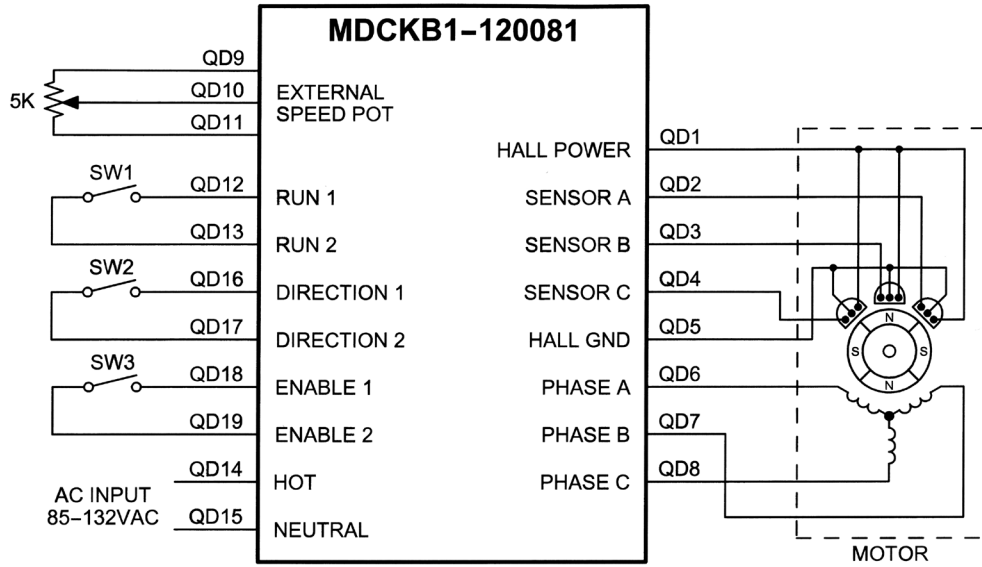

Note: The MDCKB1-120081 driver is not line isolated. Use only mechanical switches for the control inputs. The terminals of motor connector contains high voltage. Do not probe any part of the driver with power on, this could damage the drive or result in body injury.

# Dimensions

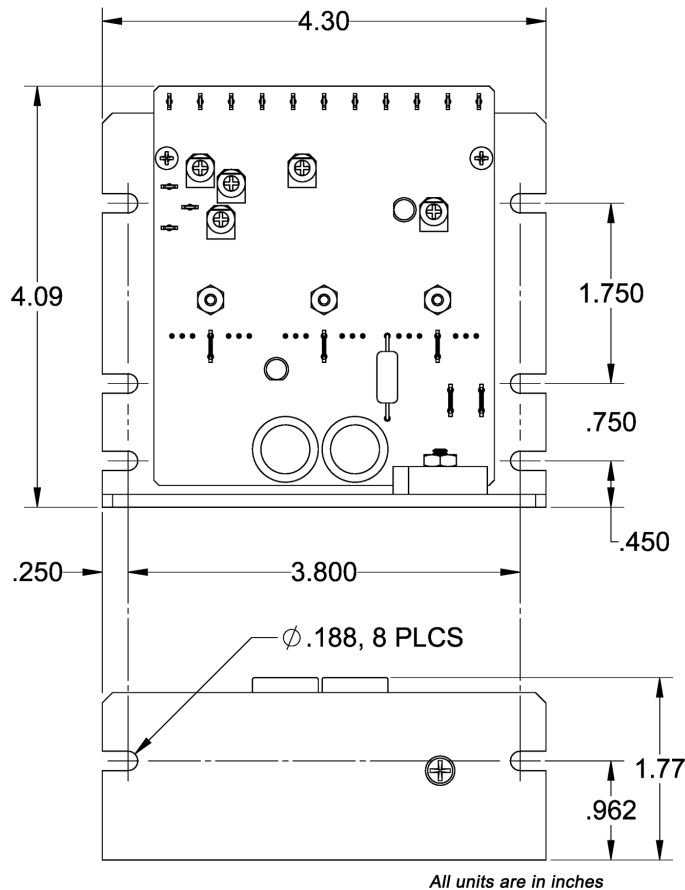



## **COPYRIGHT**

Copyright 2012 by Anaheim Automation. All rights reserved. No part of this publication may be reproduced, transmitted, transcribed, stored in a retrieval system, or translated into any language, in any form or by any means, electronic, mechanical, magnetic, optical, chemical, manual, or otherwise, without the prior written permission of Anaheim Automation, 4985 E Landon Drive, Anaheim, CA 92807.

## **DISCLAIMER**

Though every effort has been made to supply complete and accurate information in this manual, the contents are subject to change without notice or obligation to inform the buyer. **In no event will Anaheim Automation be liable for direct, indirect, special, incidental, or consequential damages arising out of the use or inability to use the product or documentation.**

Anaheim Automation's general policy does not recommend the use of its' products in life support applications wherein a failure or malfunction of the product may directly threaten life or injury. Per Anaheim Automation's Terms and Conditions, the user of Anaheim Automation products in life support applications assumes all risks of such use and indemnifies Anaheim Automation against all damages.

## **LIMITED WARRANTY**

All Anaheim Automation products are warranted against defects in workmanship, materials and construction, when used under Normal Operating Conditions and when used in accordance with specifications. This warranty shall be in effect for a period of twelve months from the date of purchase or eighteen months from the date of manufacture, whichever comes first. **Warranty provisions may be voided if products are subjected to physical modifications, damage, abuse, or misuse.**

Anaheim Automation will repair or replace at its' option, any product which has been found to be defective and is within the warranty period, provided that the item is shipped freight prepaid, with previous authorization (RMA#) to Anaheim Automation's plant in Anaheim, California.

## **TECHNICAL SUPPORT**

If you should require technical support or if you have problems using any of the equipment covered by this manual, please read the manual completely to see if it will answer the questions you have. If you need assistance beyond what this manual can provide, contact your Local Distributor where you purchased the unit, or contact the factory direct.

Note: The MDCKB1-120081 driver is not line isolated. Use only mechanical switches for the control inputs. The terminals of motor connector contains high voltage. Do not probe any part of the driver with power on, this could damage the drive or result in body injury.

**ANAHEIM AUTOMATION**